



MAXFLEX[®] XJS -FPO

FLEXIBLE SEALING SYSTEM FOR JOINTS AND CRACKS

DESCRIPTION

MAXFLEX[®] XJS-FPO is a sealing system consisted of a strip composed of flexible, polyolefin-polyethylene copolymer (FPO-PE) with two die cut edges, which is fixed to the surface using an epoxy-based adhesive, **MAXEPOX[®] JOINT** (Technical Bulletin No. 237), over joints or cracks subjected to small movements or exposed to chemicals. It assures a watertight joint while allowing the movement of the treated element, for both interior and exterior applications.

APPLICATIONS

- Waterproofing of joints on subject to permanent contact with water in channels, water reservoirs, sewage plants, swimming pools, fountains, tunnels, etc.
- Sealing and repair of wide and irregular joints subjected to movements and/or expansions.
- Waterproofing of cracks and active fissures in concrete.
- Waterproofing of junctions and corner joints in bathrooms, changing rooms, etc.

ADVANTAGES

- Totally waterproof system for joints and complete water tightness.
- Suitable for applications in permanent water immersion.
- Excellent adhesion to usual substrates and building materials used in construction.
- Very good chemical resistance: marine water, wastewater, salts, diluted acid and alkali solutions.
- Good tensile strength and elongation, providing flexibility even at low temperatures.
- Very easy to apply.

APPLICATIONS INSTRUCTIONS

Surface preparation

Substrate must be clean, sound and free from any dust, rust, oil, greases or other materials, which could affect the adhesion of the elastic system. Remove laitance, casting skins, loose or cracked parts using brushes, grinders or sandblasting methods.

Before the placement of **MAXFLEX[®] XJS-FPO**, all surface damages, such as defects, cavities, honeycombs, peggings, gravel pockets should be patched and filled with a repair mortar such as **MAXREST[®]** (Technical Bulletin No. 2). Also deteriorated joint faces should be repaired prior to placement of **MAXFLEX[®] XJS-FPO**. When using the epoxy-based adhesive, substrate must be fully dry.

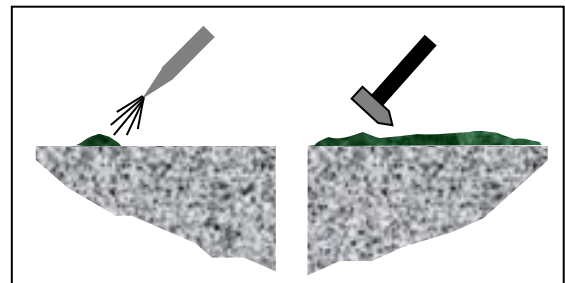

Surface preparation

Strip preparation

Using a scissor cut **MAXFLEX[®] XJS-FPO** pieces to the specified length according to the work plan. Pre-assemble all strip joints, mitres, crossing or corners before the placement. Make sure that all fleece edges are dry before applying the epoxy adhesive material.

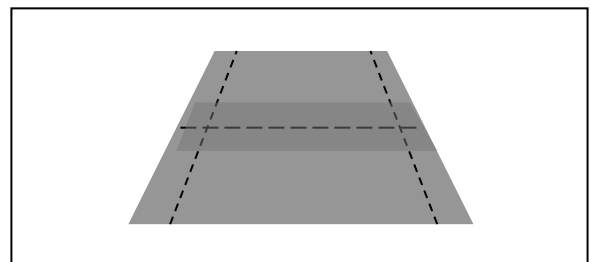

Piece preparation

Application

Application of the base bonding layer:

Using a brush, roller or trowel, apply a base layer of bonding material on the prepared substrate along the joint or crack, on each side of the joint/crack (adhesive should be extend at least 4 mm past the edge of the die cuts) to a layer thickness of about 1,0-1,5 mm.

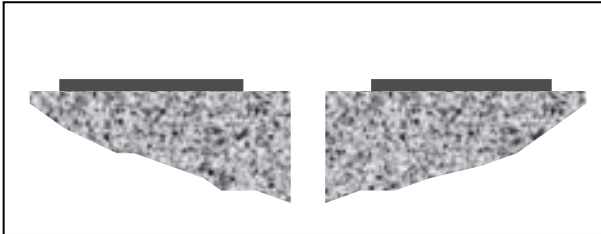

Application of the base bonding layer

Placement of the pieces:

Immediately after the base bonding layer application, the **MAXFLEX® XJS-FPO** pieces must be applied onto the adhesive material. Press firmly the pieces with a trowel or hard roller in order to allow the adhesive goes through the die cuts.

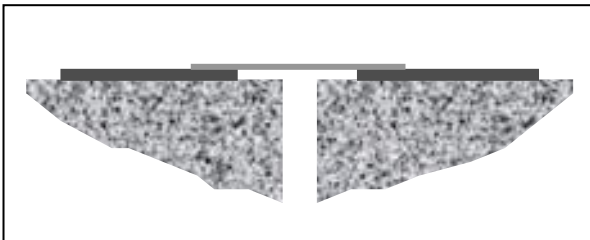

Placement of **MAXFLEX® XJS-FPO** on the base bonding layer

Application of the adhesive overcoat:

Using a brush, roller or trowel, apply the adhesive overcoat over the strips in a "wet on wet" application. These strips must not be covered with the adhesive (2-3 mm thick) in those areas without die cuts.

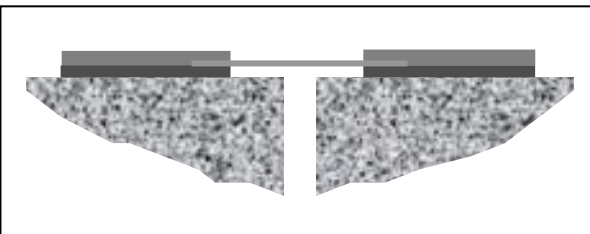

Application of the adhesive overcoat

It is not necessary to cover the flexible area with the adhesive. On **MAXEPOX® JOINT** should be sanded with silica sand.

Mechanical protection

Flexible area of **MAXFLEX® XJS-FPO** should be protected against mechanical damages in areas subjected to traffic with a stainless steel or metal sheet cover.

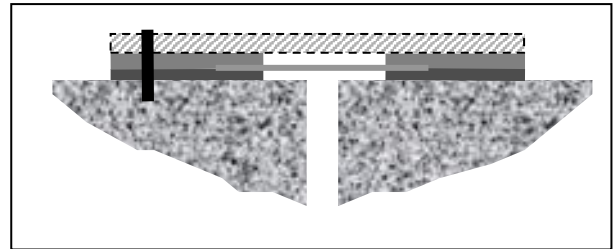

Protection of **MAXFLEX® XJS-FPO** against mechanical damages with a metal sheet

Welding pieces:

When welding two different **MAXFLEX® XJS-FPO** pieces, an overlapping with a patch of at least 5 cm length is recommended. Connections are made using a polychloroprene-based adhesive material **MAXFLEX® XJS BOND** (Technical Bulletin No. 319) or by heating means, i.e. hand welding tool. Patches for the overlapping areas are made from the flexible area of **MAXFLEX® XJS-FPO**. Surface of these patches to be joined and lap areas must be clean, dry and free from grease or dust. If cleaning agents are used, allow drying out for 30 minutes. Site tests to verify welding techniques are advisable. For hot welding, avoid to scorch (smoke and discoloration of FPO-PE copolymer is noticed) or under heating with no weld forming. For solvent welding, apply the solvent in the lap and then, using a hard roller press down the lap until it gains enough strength.

Application conditions

For bonding material, optimum application temperature range is between 5 and 25°C. Do not apply below 5°C or if lower temperatures are expected within the following 24 hours after application. Do not apply on frozen surfaces or if rain is expected 24 hours after application.

Observe application conditions for the **MAXFLEX® XJS BOND** welding material.

Curing

Curing time required to put the product into service or to immerse it in water will depend on temperature and relative humidity conditions on site. Thus, for the application with **MAXEPOX® JOINT** the curing time is 24 hours for pedestrian traffic and 7 days for permanent immersion conditions. Applications made at lower temperatures or sites without ventilation will require longer curing periods.

Cleaning

All tools and equipment can be cleaned with **MAXEPOX® SOLVENT**. Once it cures, material can only be removed by mechanical means.

CONSUMPTION

Total consumption for **MAXEPOX® JOINT**, is about 0,7 to 0,8 kg/linear meter. These figures may vary depending on substrate conditions. A preliminary test on-site will determine the coverage exactly.

PACKAGING

MAXFLEX® XJS-FPO is supplied in two different widths (200 mm and 250 mm), in colour grey in 20 m long rolls.

STORAGE

Twenty-four months, in its original packaging, in a dry and covered place, protected from frost.

IMPORTANT INDICATIONS

- Prior to using other adhesives, check compatibility and suitability for these materials.
- For any clarification or additional information, please consult our Technical Department.

SAFETY AND HEALTH

MAXFLEX® XJS-FPO is not a hazardous product, but the precautions indicated in the technical bulletins for the bonding materials used must be observed.

Safety Data Sheet for **MAXFLEX® XJS-FPO**, **MAXEPOX® JOINT** and **MAXFLEX® XJS BOND** are available by request.

Disposal of the product and its empty packaging must be made by the final user and according to official regulations.

TECHNICAL DATA

Characteristics of product	MAXFLEX® XJS-FPO
Description	Flexible, polyolefin-polyethylene copolymer belt (FPO-PE) with die cut edges
Color	Grey
Width, (mm)	200 y 250
Mass per unit area, (g/m ²)	950
Thickness, (mm)	1,0
Breaking load – Tensile strength, DIN EN ISO 527-3 (N/15 mm – N/mm ²) - Longitudinal/Transverse	187 -12,0 / 192 – 12,1
Elongation at break Longitudinal / Transverse, DIN EN ISO 527-3 (%)	392 / 992
Shore A hardness (DIN 53505)	87
Energy absorption at 25/50 % for side elasticity, DIN EN ISO 527-3 (N/mm)	4,0 / 4,5
Resistance to water pressure (1,5 bar at 7 days), DIN EN 1928	> 3,0 bar
Peel strength on plywood, DIN EN ISO 527-3 (N/50 mm)	> 100
Bond strength, DIN EN 1348 (N/mm ²)	4,0
Tear strength -Longitudinal/Transverse-, DIN EN 12310-2 (N)	94 / 124
Suitability for contact with potable water European Directive 2020/2184 and Spanish RD 03/2023	Approved

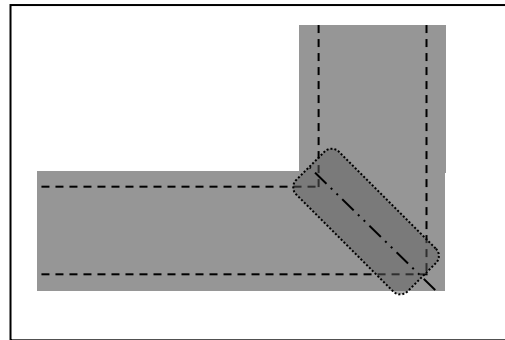
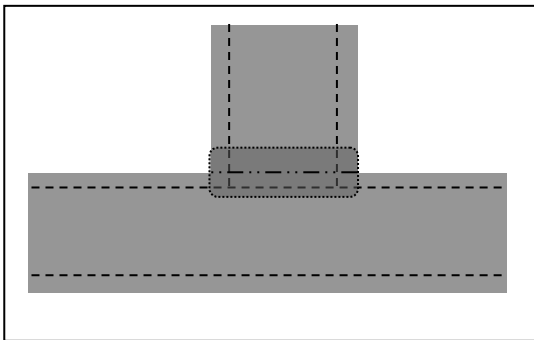
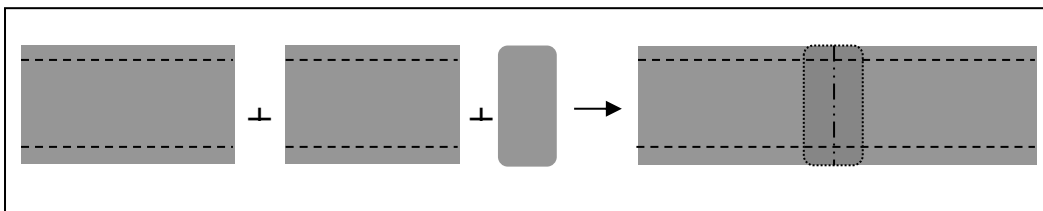
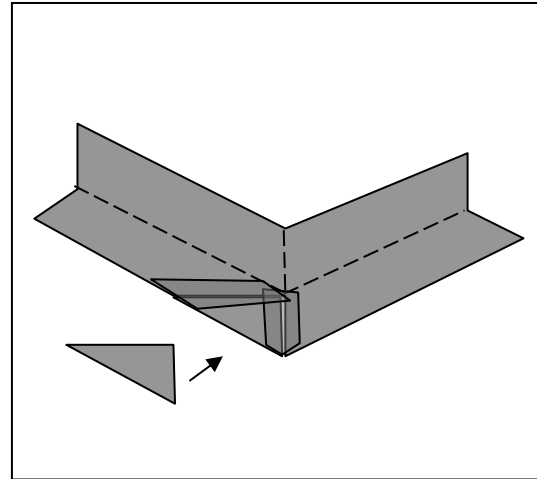
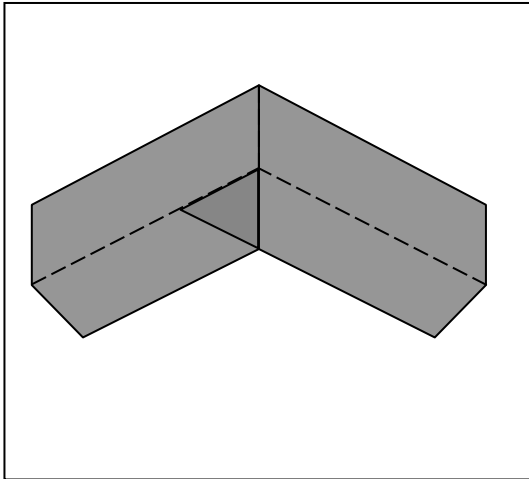

GUARANTEE

The information contained in this leaflet is based on our experience and technical knowledge, obtained through laboratory testing and from bibliographic material. **DRIZORO®**, **S.A.U.** reserves the right to introduce changes without prior notice. Any use of this data beyond the purposes expressly specified in the leaflet will not be the Company's responsibility unless authorised by us. We shall not accept responsibility exceeding the value of the purchased product. The data shown on consumptions, measurement and yields are for guidance only and based on our experience. These data are subject to variation due to the specific atmospheric and jobsite conditions so reasonable variations from the data may be experienced. In order to know the real data, a test on the jobsite must be done, and it will be carried out under the client responsibility. We shall not accept responsibility exceeding the value of the purchased product. For any other doubt, consult our Technical Department. This version of bulletin replaces the previous one.



DRIZORO, S.A.U.

C/ Primavera 50-52 Parque Industrial Las Monjas
28850 TORREJON DE ARDOZ - MADRID (SPAIN)
Tel. +34 91 676 66 76 - +34 91 677 61 75
e-mail: info@drizoro.com Web site: drizoro.com